

MULTI-CLEAN®

U.S. PATENT NO. 4,365,377

HI-BUFF FLOOR MACHINE
ASSEMBLY NO. 830910
STARTING SERIAL NO. 388289

*Hi-Speed unit
w/o adjustable center
wheel - only spring loaded
Cup is (2) sheet metal screws
held on driver - Cup # 831094*

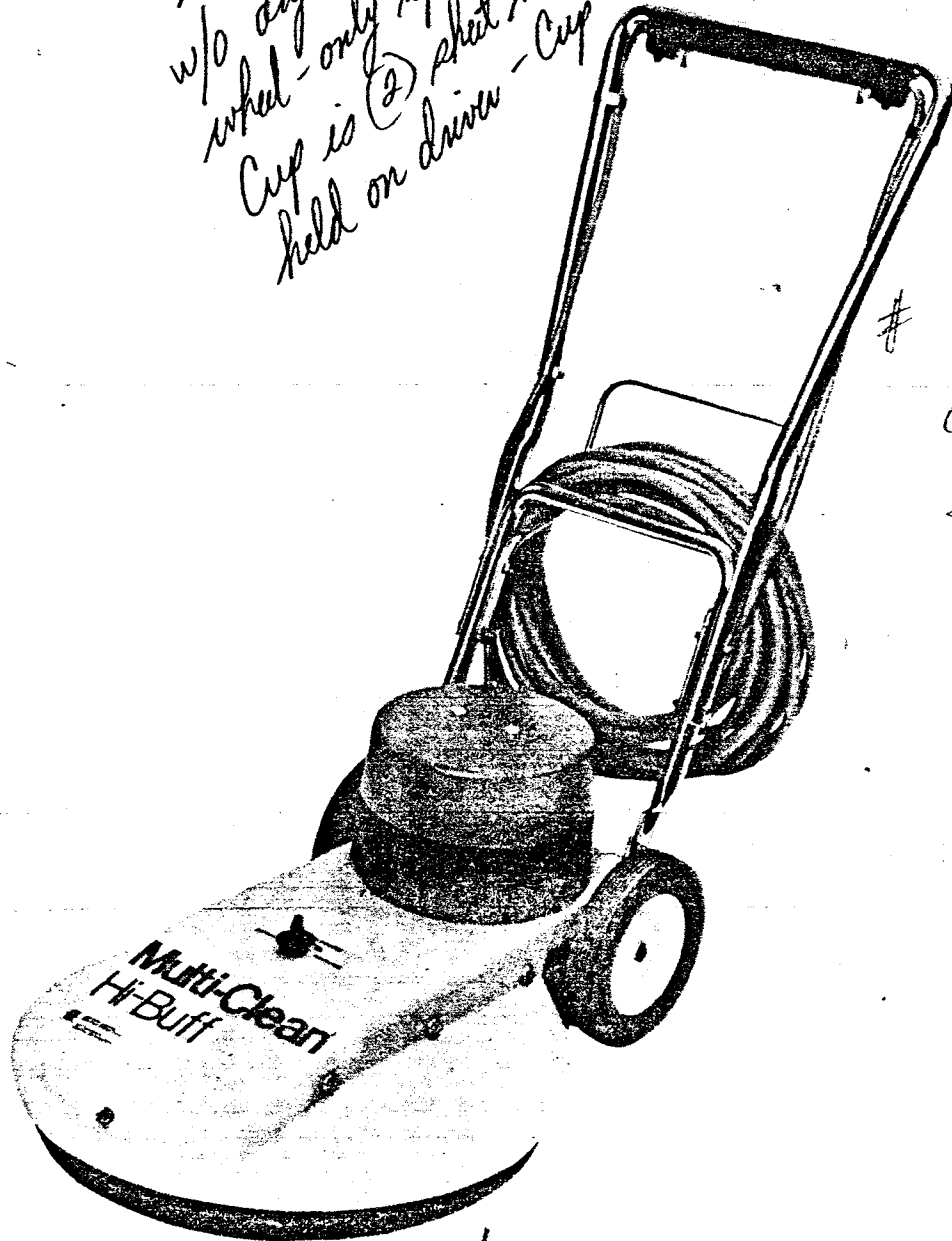

*ORIGINAL MAC
NO ADS KN
831090
CASTER ASSY.
SPRINGS PROG
ONLY.*

Multi-Clean, Inc.

2277 Ford Parkway
Saint Paul, Minnesota 55116
(612) 698-8833

FORM 825308

Aug 24, 1984

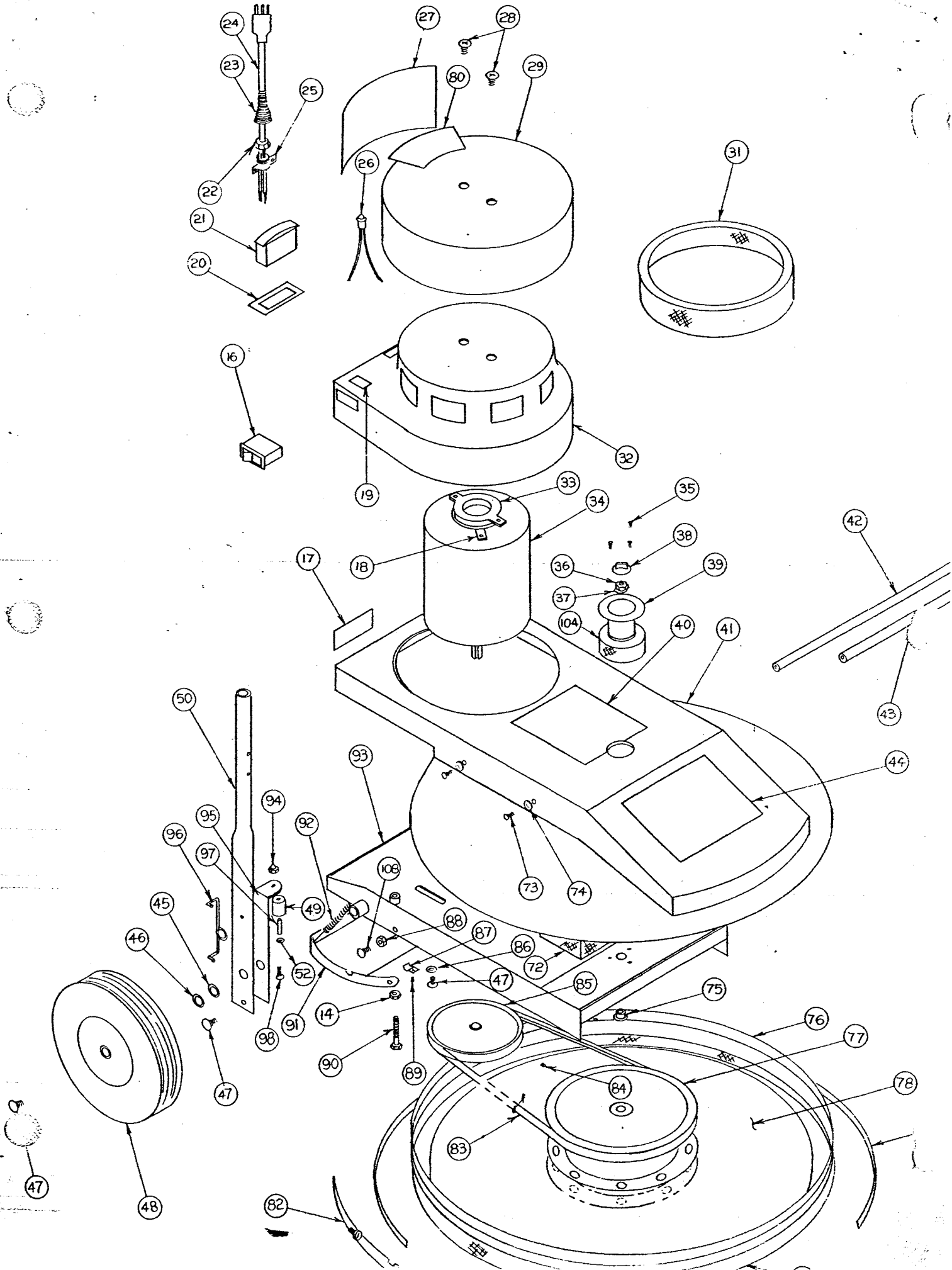

ITEM	PART NO.	QTY	DESCRIPTION	ITEM	PART NO.	QTY	DESCRIPTION
1	831948	1	Supply Cord	60	831542	1	Spring
2	831053	1	Spring Clip	61	832186	1	Thrust Bearing
3	832598	2	Spring	62	831852	1	E Ring
4	829130	2	Clip	63	831089	2	Bushing
5	832564	2	Gasket	64	787791	1	Shaft - Brush
6	830932	1	Switch	65	831099	1	Caster Weld
7	832576	2	Spacer	66	832467	1	Pin - Caster
8	811882	2	½-20 Cap Nut	67	832469	1	Push Ring
9	832553	1	Switch Box	68	831096	1	Wheel
10	812023	2	½-20x1½ Allen HD Screw	69	832430	1	Pad Holder Assy
11	832617	2	Spring Clip	70	832448	3	Shoulder Screw 8-32
12	832550	1	Tube Handle Top	71			
13	832551	1	Cord Wrap	72	832626	4	Bottom Dampener
14	811878	7	Flange Locknut 5/16-18	73	811432	4	Screw ¼-20x3/4
15	832606	1	Handle Cord	74	812123	5	Washer C'SK
16	832586	1	Circuit Breaker	75	832554	1	Flange Bushing
17	830939	1	Name Plate	76	832543	4*1	Air Guard
18	811402	2	Screw ¼-20x3/8	77	830965	1	Brush Pulley Assy
19	832603	1	Decal Reset	78	830917	1	Pad Driver Assy
20	832618	1	AMP Gauge Clip	79	832601	*1	Clamp Band 66"
21	832552	1	AMP Gauge	80	832627	1	Caution Decal
22	829083	1	Strain Relief Nut	81	832600	*1	Air Guard Pad Mat'1
23	700823	1	Strain Relief Spring	82	832602	*1	Clamp Connector
24	832605	1	Motor Pigtail	83	830907	1	V-Belt A-37
25	829082	1	Clamp	84	812019	2	Set Screw
26	832245	1	L.E.D. Indicator	85	830904	1	Pulley
27	831135	1	Decal Filter	86	811892	4	Flatwasher
28	811543	2	Scr 5/16-18x½	87	832623	1	Spring Clamp
29	829194	1	Top Cover	88	811983	2	Locknut 3/8-16
30				89	811101	1	10-24 UNC x5/8
31	832561	1	Filter	90	811503	2	5/16-18x1½ Cap Screw
32	832548	1	Motor Shroud	91	832609	1	Handle Lock Guard
33	829147	1	Coupling	92	832619	1	Spring
34	832110	1	Motor Assy	93	832545	1	Base Weldment
35	811142	3	10-24x½ Truss HD Screw	94	811867	1	10-24 Cap Nut
36	880023	1	Locknut 3/4	95	832620	1	Actuator Strut
37	812104	1	Lockwasher 3/4	96	832621	1	Strut Spring
38	832418	1	Knob w/ 5/16-18 Insert	97	832622	1	Roll Pin
39	832549	1	Cup	98	811059	1	Screw 10-24x1½
40	832594	1	Decal - Pad Pressure	99	829570	2	Rectifier
41	832547	1	Brush Shroud	100	829571	1	Carbon Brush (Set of
42	832599	1	Axle	101			
43	832581	1	Bottom Handle Lock Brace	102	832587	1	Resistor L.E.D. Asm
44	830947	1	Decal	103			
45	700435	2	Spring Washer	104	832624	1	Dampener
46	811958	2	Flat Washer	105	832070	1	Splice Connector
47	811636	8	Scr 3/8-16x5/8 w/Nylock	106	831514	1	Lead
48	804452	2	Wheel 8"	107	832635	3	Velcro 6"
49	832625	2	Switch Wheel	108	811067	2	Screw 3/8-16x1
50	832577	2	Bottom Handle Strut			*	Optional Item
51	811063	1	Screw Selt Tap #10-24				
52	811916	1	Washer				
53	832562	1	Lead Assy				
54	832366	3	Terminal				
55	830413	3	Terminal Insulated				
56							
57	832453	1	Adjustment Screw				
58	832412	1	Plug				
59	811917	1	Flat Washer				

ITEM	PART NO.	QTY	DESCRIPTION
1	831948	1	Supply Cord
2	831053	1	Spring Clip
3	832598	2	Spring
4	829130	2	Clip
5	832564	2	Gasket
6	830932	1	Switch
7	832576	2	Spacer
8	811882	2	1/2-20 Cap Nut
9	832553	1	Switch Box
10	812023	1	1/2-20x1 1/2 Allen HD Scr
11	832617	2	Spring Clip
12	832550	1	Tube Handle Top
13	832551	1	Cord Wrap
14	811979	4	Flange Locknut 5/16-
15	832606	1	Handle Cord

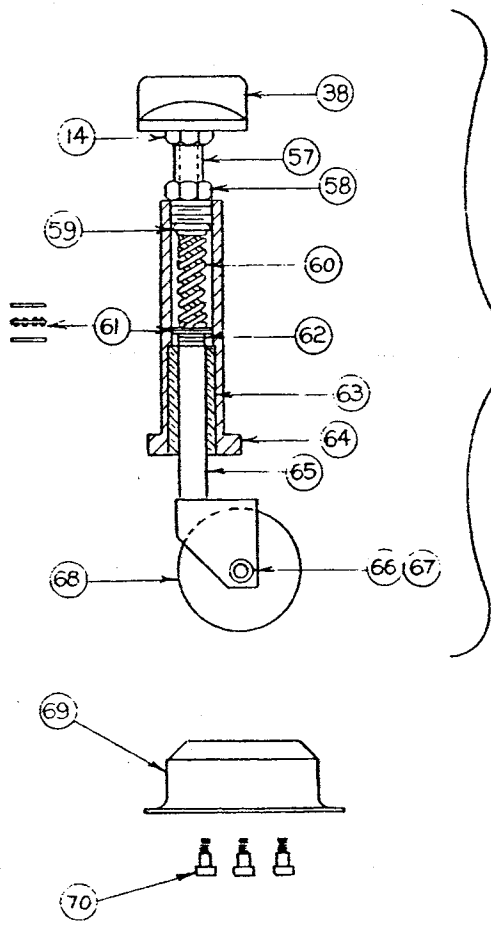
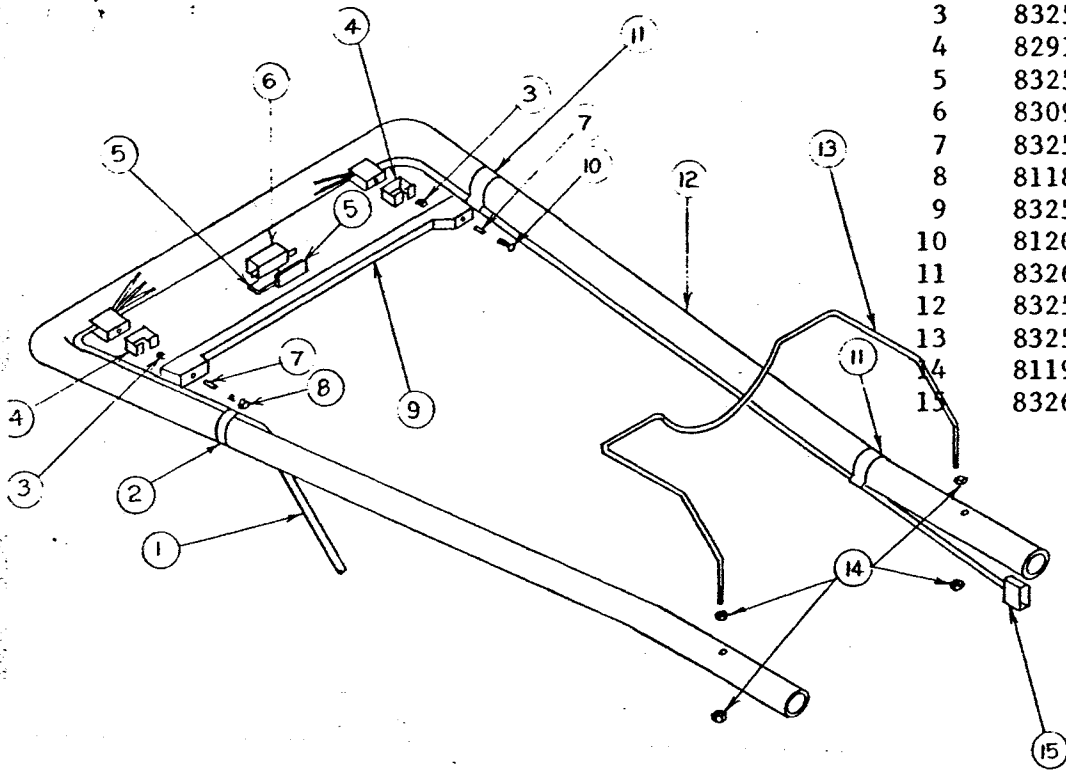

832477

832477 Caster Tube Asm.

ITEM	PART NO.	QTY	DESCRIPTION
14	811979	1	Flange Locknut 5/16-18
38	832418	1	Knob w 5/16-18 Insert
57	832453	1	Adjustment Screw
58	832412	1	Plug
59	811917	1	Flat Washer
60	831542	1	Spring
61	832186	1	Thrust Bearing
62	831852	1	E Ring
63	831089	2	Bushing
64	787791	1	Shaft-Brush
65	831099	1	Caster Weld
66	832467	1	Pin-Caster
67	832469	1	Push Ring
68	831096	1	Wheel
69	832430	1	Pad Holder Assy
70	832448	3	Shoulder Screw 8-32

Older style 1st. Generation
Pad holder 2 studs - screws

BRUSH PULLEY ASSY 830965

ITEM	PART NO.	QTY	DESCRIPTION
1	786971	1	Pulley-Machined
2	881060	2	Bearing
3	881317	2	Snap Ring
4	812019	3	Set Screw #10-32
5	832448	3	Shoulder Screw

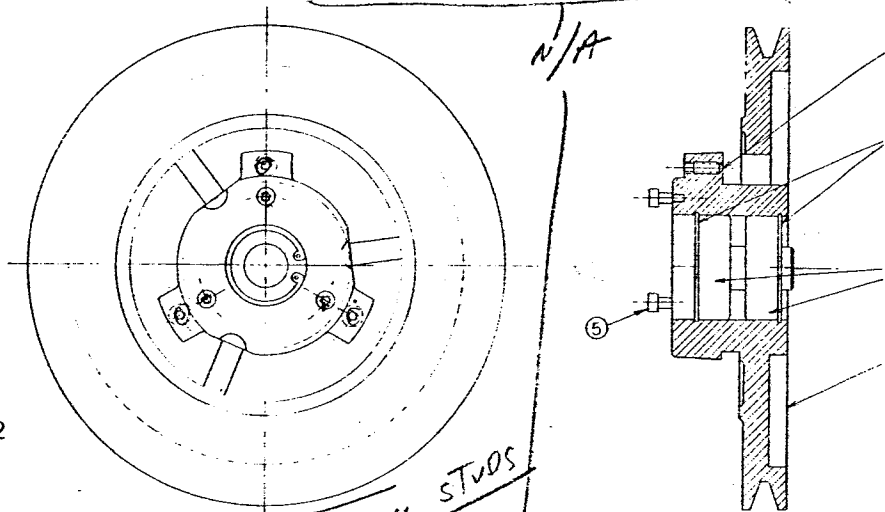

old aluminum studs will UNSCREW use 3-# 832448 shoulder screws
2 Hole twist # 832448 lock cap.
very old changed in 1983

PAD HOLDER ASM. 832430

ITEM	PART NO.	QTY	DESCRIPTION
1	831094	1	Pad Holder
2	832417	1	Coupling
3	827667	3	Pop Rivet

3 Hole Cup

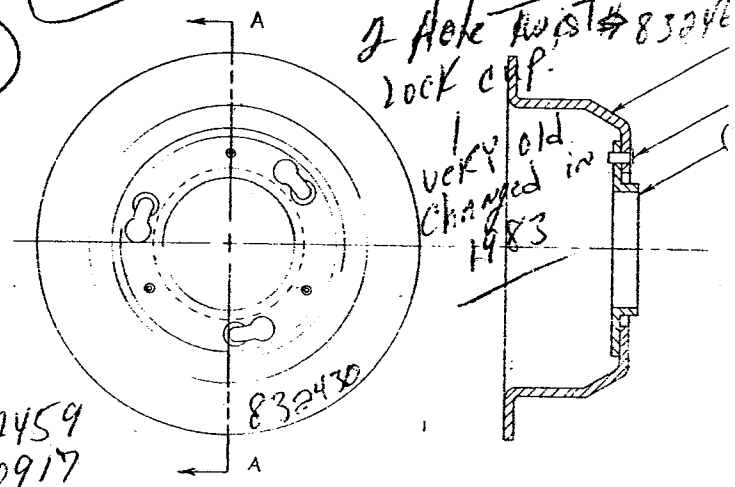

PAD DRIVER ASSY. 830917

ITEM	PART NO.	QTY	DESCRIPTION
1	832419	2	Pad Holder Spinning
2	830925	1	Pad Driver
3	832178	1	Pad Holder
4	402	1	Clutch Plate
5	811423	3	Screw 1/2-20x1
6	812100	3	Nut, Lock 1/2-20

Replaced By 833205 - used some

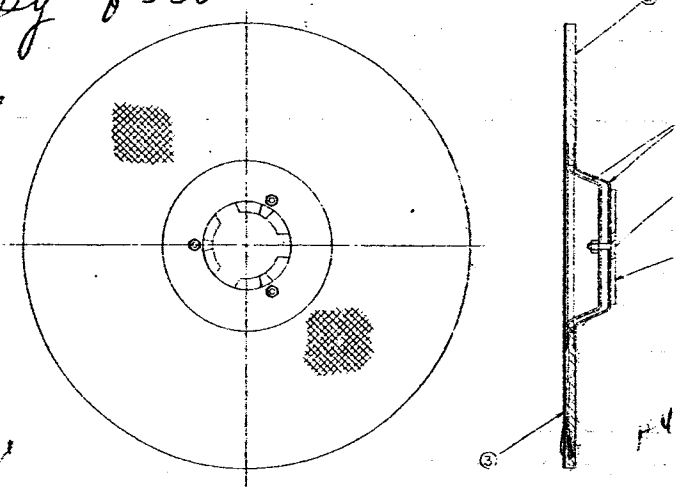

NOTE: TO CONVERT ALL OLD STYLE DRIVERS TO # 833900 DRIVER, USE KIT PART # 750084.

833664 Yellow Part Ring.
PAD Gripper kit.